

Vertical Air Receivers

Allied Air Products and Services offer a popular range of vertical air receivers that are specifically designed for use in industrial compressed air systems.

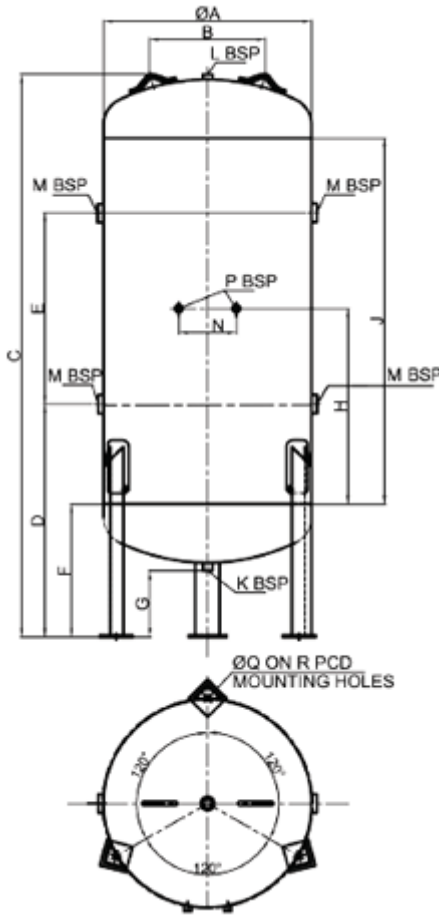

- ✓ Designed, manufactured and tested in accordance with Australian Standard AS 1210.
- ✓ Manufacturer's Data Report provided in accordance with Australian Standard AS 4458.
- ✓ OH&S Registered Design approved for workplace use in all Australian States and Territories.
- ✓ Industry preferred socket sizes and placement Reinforced vessel support attachments.
- ✓ External surfaces are abrasive blast cleaned, primed, finish coated in two pack polyurethane paint and then oven dried.
- ✓ Blue external colour (similar to Dulux® Process Blue) indicates compressed air content in accordance with Australian Standard AS 1345.
- ✓ Individually packed in a horizontal position inside a full timber crate with plastic bag cover.



Specifications

PRODUCT CODE	VOLUME Litres	DESIGN PRESSURE kPa	DIMENSIONS																WEIGHT kg
			A	B	C	D	E	F	G	H	J	K	L	M	N	P	Q	R	
FS V150LP	150	1,320	390	214	1,700	750	450	375	250	622	1,200	1/2	3/4	1-1/2	150	1/2	14	388	72
FS V330LP	330	1,210	490	250	2,210	780	900	405	250	825	1,650	1/2	3/4	1-1/2	150	1/2	14	505	125
FS V530LP	530	1,280	640	348	2,140	820	750	445	250	750	1,500	1/2	3/4	2	150	1/2	14	667	200
FS V820LP	820	1,154	780	360	2,215	875	720	500	250	735	1,470	3/4	3/4	2	150	1/2	18	791	300
FS V1240LP	1,240	1,035	975	500	2,213	889	690	514	250	720	1,440	3/4	1	2	150	3/4	18	967	430

- Design temperature range: 0°C to 100°C.
- Design fluid contents: Air..
- All socket threads are BSPP.
- Specifications are subject to change without notice.